

BATHROOM

FRANCIS
PROJECT

francistaps.co.uk

Contents

Detail

About us	4-5
Our Guarantee	6
Design, Approvals & Standards	7
Unified Water	8-9
Feature Identifiers	10-11

Bathroom Taps & Mixers

Araya Castillo	14
Araya Lujo	15
Araya Urban	16
Araya Modern	17
Araya QT	18
Mercia Traditional	19
Mercia QT	20
Mercia Modern	21

Showers

Thermostatic Shower Mixers	24
Sliding Bar Sets & Shower Kits	25
Tech Air Shower Heads	26
Concealed Shower Mixers	27

Commercial

Electric Sensor Mixers	30
Thermostatic Basin Mixer	30
Non-Concussive	31
Healthcare Solutions	33

Accessories

Basin Wastes & Traps	36-37
Bath Wastes	38
Sink Wastes	39
Shower Wastes	39
Shower Accessories	40
Anti Scold Thermo Mixing Valves	40
Tap Conversion Kits	40
Flow Restrictors	41
Copper Inlet Tails	41
Replacement Filters	41

Terms & Conditions

42-43

FRANCIS

PROJECT

Renowned for innovative and practical designs, with a portfolio of products created to suit the needs and expectations of our market. Combining style with practicality, our market-leading products are designed, developed and manufactured using the best materials available. We also apply stringent quality control standards to ensure outstanding reliability and the assurance of a long and robust working life.

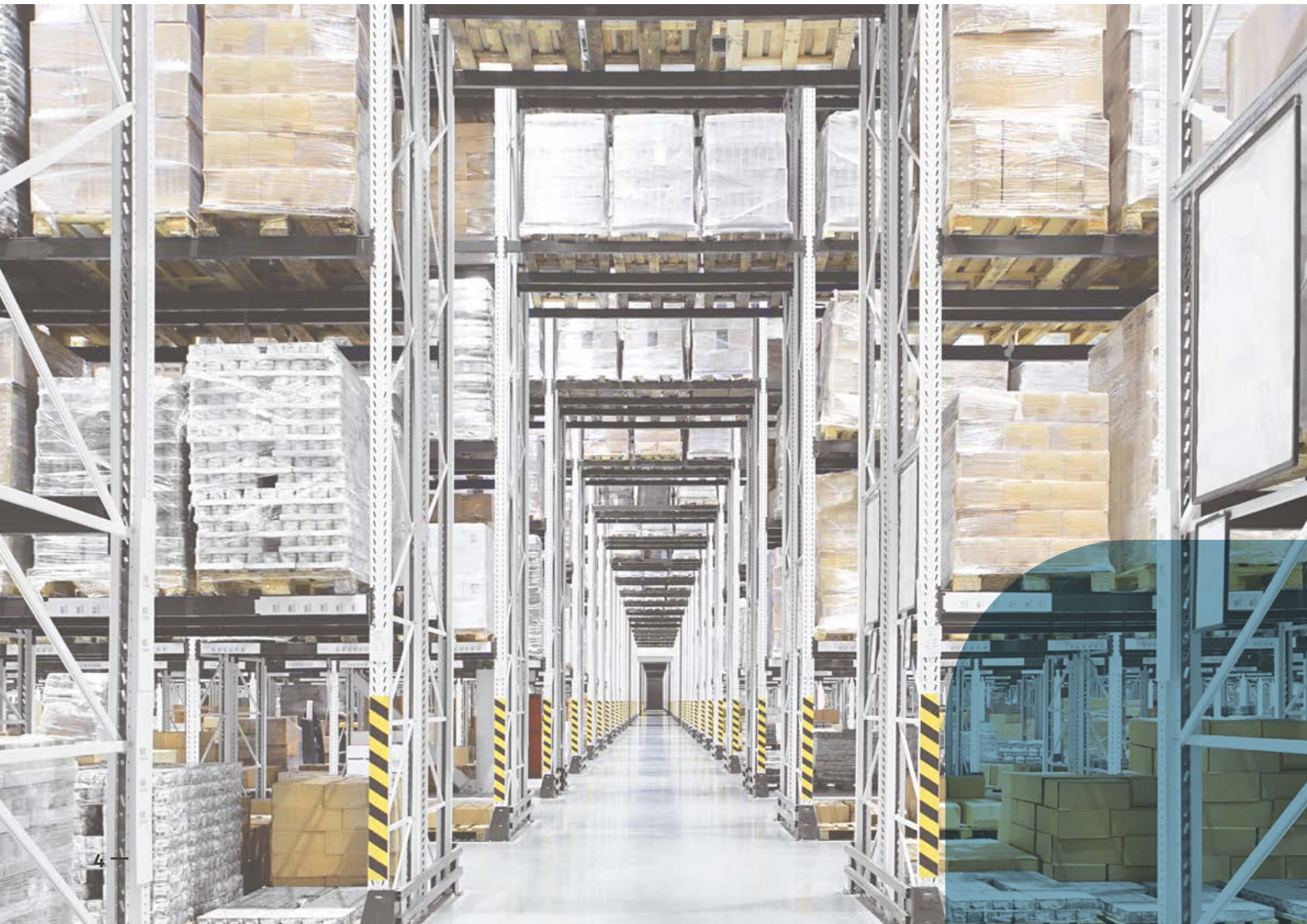

A History of Heritage and Design

1899

Francis inherited the Northern Rubber Co but he was keen to expand the business. He met Fred Birchall, who had gained experience as a brass founder at the Hexthorpe Brass and Iron works in Doncaster, and rose through the ranks to become manager. Francis agreed to put up the money for Fred to start a new operation and Francis and his brother established a corporation.

Using the latest methods at the time, they soon expanded from manufacturing products for the steam industry to manufacturing other complex valves. One of the catalysts for this expansion was the screw down tap. The tap was invented in 1845 but had not been successfully mass-produced before Francis's inception.

1913

Fred Birchall wanted to have the most advanced factory in the country and took a trip to the USA in order to look at the world's most advanced manufacturing companies of the time. On his return he introduced revolutionary manufacturing techniques. Followed by a more sophisticated quality control system the following year. Carefully designed packaging brought products to customers in perfect condition, another concept way ahead of its time.

1940's -
60's

Moving into the 1940's Francis developed the UK's first auto shut off taps which was a major advancement in tap design. Moving into the 1950's Francis began to design taps to British Standard 1010, and then in the 60's Francis introduced compact non rising headwork's in luxury taps.

1990's

A design collaboration with Porsche for luxury tap ranges, leading the way for premium and stylish taps in today's market.

2019

Francis brand is transferred to Standard Hidraulica Group (STH Westco in the UK), creating a centre of excellence for taps, mixers and showers. The brand has evolved into Francis Kitchen & Bathroom and to make your experience with us more tailored to your specific needs, we've separated our brand into three categories; Francis Platinum, Francis Design and Francis Project.

**DESIGNED & SUPPLIED
WITH YOU IN MIND**



Our Guarantee

When you purchase or specify any Francis product, you are acquiring far more than a means of doing a job well. You are investing in unrivalled quality, service, value and reliability that has been over 100 years in the making.

TERMS AND CONDITIONS

Products are subject to a 2, 5 or 10 year guarantee that is between Francis and the final purchaser of the product.

The guarantee is subject to proof of purchase being supplied.

This guarantee does not affect any statutory rights the consumer may have in law.

The guarantee covers manufacturing or material defects and does not cover parts subject to normal wear and tear.

Finishes other than chrome are covered for a period of 3 years only and the guarantee on the finish is subject to the cleaning instructions being followed.

The guarantee is not applicable where the product is fitted contrary to the conditions in the fitting instructions.

Abusive behaviour and accidental damage to the product are not covered by this guarantee.

The extent of this liability is limited to the cost of the replacement of the defective item and not to fitting or consequential damages.

2
YEAR

Guarantee

5
YEAR

Guarantee

10
YEAR

Guarantee



Design, Approvals & Standards

We are dedicated to designing, developing and manufacturing products of the highest quality. Our products, where applicable, comply with the relevant British, European and International standards.



MANUFACTURING QUALITY

By using the very best materials currently available and applying the most stringent quality control standards, we can consistently deliver outstanding product reliability leading to the assurance of a long working life.

CONTINUOUS IMPROVEMENT

Continual improvement is a key ingredient of the standard. Maintaining a policy of continual product development, Francis reserve the right to change specifications, design, and materials of products listed in this catalogue without prior notice. It is therefore mandatory that all aspects of the business strive for improvement year on year to ensure that customer satisfaction is increased with a subsequent improvement in business performance.

FRANCIS PROJECT

NEOPERL®

flow, stop and go®

As part of our environmental commitment to reduce water usage many of our platinum level products are now fitted with a Neoperl PCA Dual Core aerator.

This allows for early aeration at lower pressure, giving users a full and pleasant water stream whilst limiting the flow at higher pressure to reduce water usage without reducing performance.

We understand that sometimes a flow straightener will still be required and this option can be found as part of the fitting kit supplied.

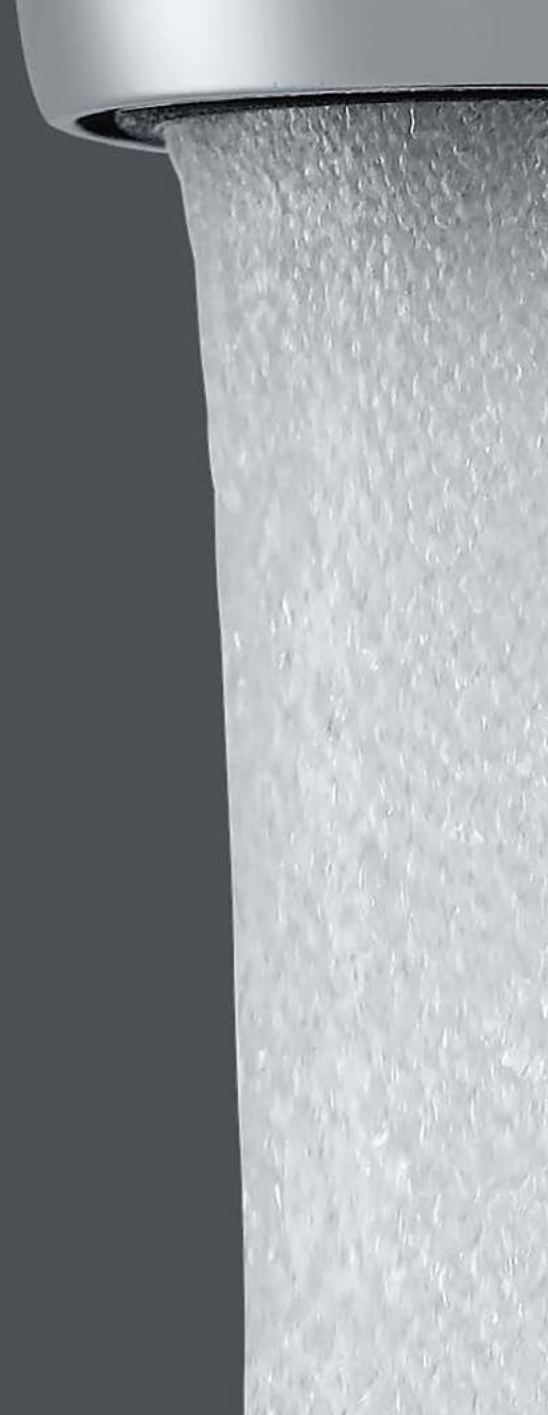

The Unified Water Label

The aim of the Unified Water Label for consumers is an easy to identify and simple to understand label detailing water consumption to allow for an informed choice. For manufacturers, the aim is to promote use of smart technology for products that deliver on performance whilst providing consumers with sustainable products.

The following Smart Eco technology is included in our products where these symbols are displayed.

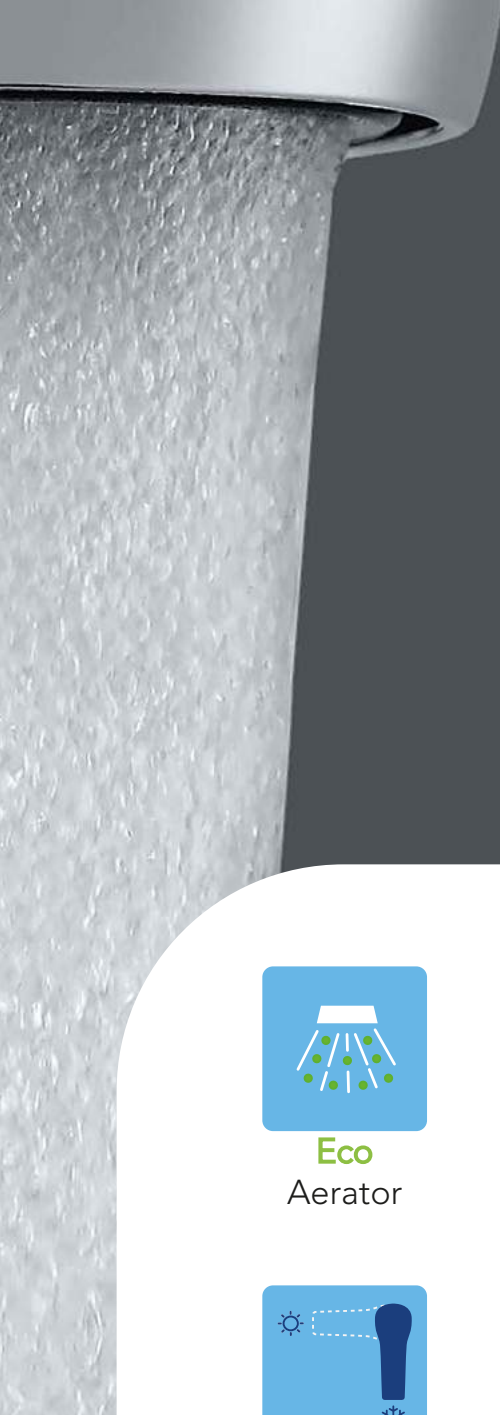

Eco
Aerator

Eco Aerator: The Neoperl PCA Dual core aerators limit maximum flow to 5L/Min for bathroom and 8L/Min for kitchen products whilst comfort of usage remains the same.



Cold
Open

Cold Open: The Cold Open cartridge system ensures mixers open with cold water only avoiding the unnecessary use of hot water to deliver energy savings. The one way opening also prevents any potential clash with tiles or backboards.

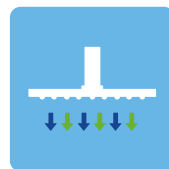

Tech Air
Rain Shower

Tech Air: The advanced Tech Air system mixes air with incoming water to reduce water consumption by at least 30% in our shower products and offers a softer and more comfortable water spray.

The following icons can also be found alongside product information to show flow rate when tested against minimum recommended pressure.

Tested at
0.2 bar



Tested at
0.5 bar



Tested
at 3 bar



Feature Identifiers

We have created a range of easy to identify icons to allow for quick feature comparison.



Guarantee

Product Guarantee. See terms & conditions.



Guarantee

Product Guarantee. See terms & conditions.



Low Pressure

Suitable for systems 0.1 bar + and above.



Medium Pressure

Suitable for systems 0.5 bar + and above.



High Pressure

Suitable for systems 1 bar + and above.



Eco Aerator

Mixes water with air to reduce water consumption whilst maintaining a pleasant stream at both low and high pressures.



Flow Aerator

Mixes air with water to give a bubbling effect to the flow of water. Recommend at 1 bar +.



Flow Straightener

Ensures flow of water is directed at outlet.



Dual Spray

Model contains an additional spray function to compliment standard outlet flow.



Single Flow

Hot and cold water mixes in model for single flow at outlet.



Cold Open

Mixer opens with cold water only, avoiding unnecessary used hot water.



Pull Out

Model has a pull out spout feature.



Magnetic Dock

Spout attaches to mixer via magnetic dock.



Easy Fix

Product can be fixed to basin / sink without need for tools.



Superfix

Provides additional stability around installation area (Kitchen models only).



98°C

Model can deliver hot water up to 98°C.



Child Safety

Prevents accidental operation of hot water feature.



Cold Touch

Anti scold technology featured within the product.



Filtered

Model contains a filter for improved taste and odour on the cold feed.

Bathroom Taps & Mixers





Product range

	Pages
Araya Castillo	14
Araya Lujo	15
Araya Urban	16
Araya Modern	17
Araya QT	18
Mercia Traditional	19
Mercia QT	20
Mercia Modern	21

ARAYA CASTILLO

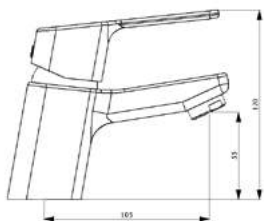

CODE DESCRIPTION
922312 Mono Basin Mixer

Flexible Hose
 Low Pressure
 10 YEAR Guarantee
 Flow Straightener
 Flow Aerator
 Single Flow
 5.5 l/min

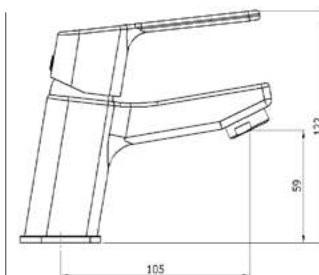

CODE DESCRIPTION
922311 Slim Mono Basin Mixer

Flexible Hose
 Low Pressure
 10 YEAR Guarantee
 Flow Aerator
 Flow Straightener
 Single Flow
 4.7 l/min

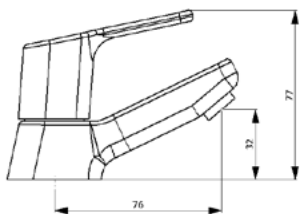

CODE DESCRIPTION
922309 Basin Tap Pair

Metal Backnut
 Low Pressure
 10 YEAR Guarantee
 Flow Straightener
 Single Flow
 15.5 l/min

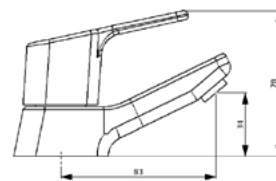

CODE DESCRIPTION
922310 Bath Tap Pair

Metal Backnut
 Low Pressure
 10 YEAR Guarantee
 Flow Straightener
 Single Flow
 15.3 l/min

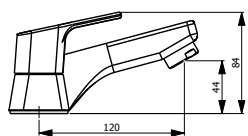

CODE DESCRIPTION
922314 Bath Filler

Metal Backnut
 Low Pressure
 10 YEAR Guarantee
 Flow Straightener
 Single Flow
 14.7 l/min

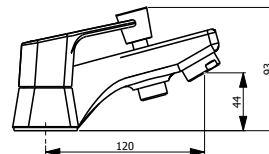

CODE DESCRIPTION
922315 Bath Shower Mixer With Shower Kit

Metal Backnut
 Low Pressure
 10 YEAR Guarantee
 Flow Straightener
 Single Flow
 Shower Kit Included
 11.3 l/min

ARAYA LUJO

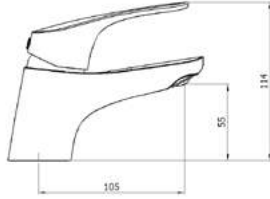

CODE DESCRIPTION
922303 Mono Basin Mixer

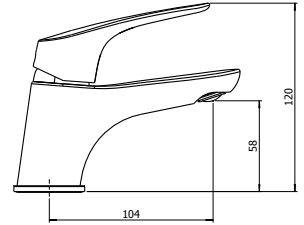

CODE DESCRIPTION
922302 Slim Mono Basin Mixer

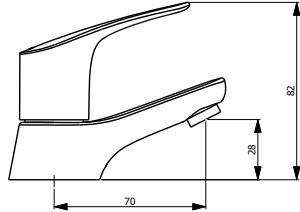

CODE DESCRIPTION
922300 Basin Tap Pair

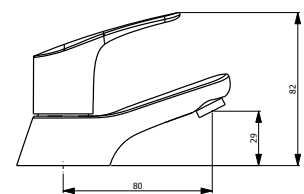

CODE DESCRIPTION
922301 Bath Tap Pair

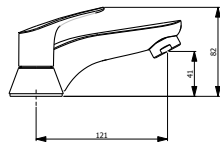

CODE DESCRIPTION
922305 Bath Filler

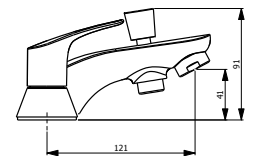

CODE DESCRIPTION
922306 Bath Shower Mixer With Shower Kit



ARAYA URBAN

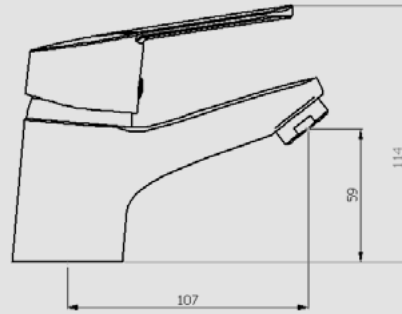

CODE	DESCRIPTION
4S1205	Mono Basin Mixer

- Flexible Hose
- Low Pressure
- 10 YEAR Guarantee
- Flow Straightener
- Flow Aerator
- Single Flow
- 4.9 l/min

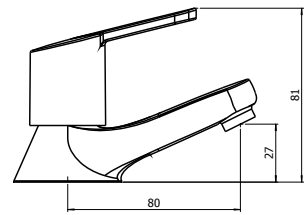
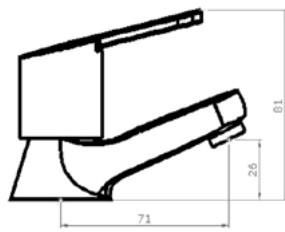

CODE	DESCRIPTION
4S1201	Basin Tap Pair

- Metal Backnut
- Low Pressure
- 10 YEAR Guarantee
- Flow Straightener
- Single Flow
- 12.8 l/min

CODE	DESCRIPTION
4S1202	Bath Tap Pair

- Metal Backnut
- Low Pressure
- 10 YEAR Guarantee
- Flow Straightener
- Single Flow
- 14.9 l/min

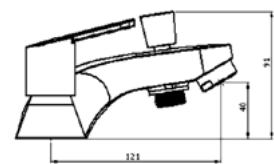
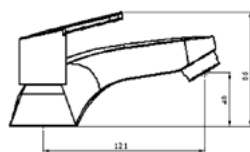

CODE	DESCRIPTION
4S1203	Bath Filler

- Metal Backnut
- Low Pressure
- 10 YEAR Guarantee
- Flow Straightener
- Single Flow
- 15.1 l/min

CODE	DESCRIPTION
4S1204	Bath Shower Mixer With Shower Kit

- Metal Backnut
- Low Pressure
- 10 YEAR Guarantee
- Flow Straightener
- Single Flow
- Shower Kit Included
- 10.3 l/min

ARAYA MODERN

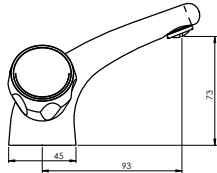

CODE DESCRIPTION
922034 Mono Basin Mixer



Flexible Hose



Low Pressure



2 YEAR Guarantee



Flow Straightener



Single Flow



10.1 l/min

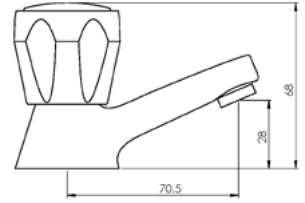

CODE DESCRIPTION
922031 Basin Tap Pair



Metal Backnut



Low Pressure



2 YEAR Guarantee



Flow Straightener



Single Flow



18.7 l/min

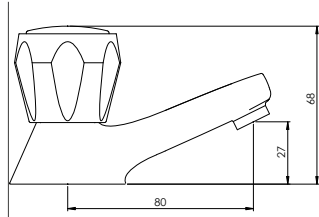

CODE DESCRIPTION
922033 Bath Tap Pair



Metal Backnut



Low Pressure



2 YEAR Guarantee



Flow Straightener



Single Flow



22.1 l/min

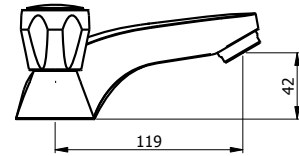

CODE DESCRIPTION
922041 Bath Filler



Metal Backnut



Low Pressure



2 YEAR Guarantee



Flow Straightener



Single Flow



25.5 l/min

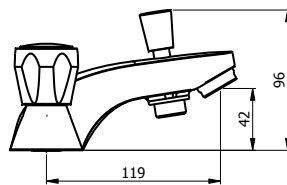

CODE DESCRIPTION
922036 Bath Shower Mixer With Shower Kit



Metal Backnut



Low Pressure



2 YEAR Guarantee



Flow Straightener



Single Flow



Shower Kit Included



14.5 l/min

ARAYA QT

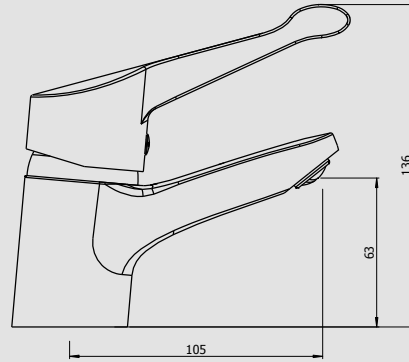

CODE	DESCRIPTION
922064	Mono Basin Mixer

- Flexible Hose
- Low Pressure
- 2 YEAR Guarantee
- Flow Straightener
- Single Flow
- 5.7 l/min

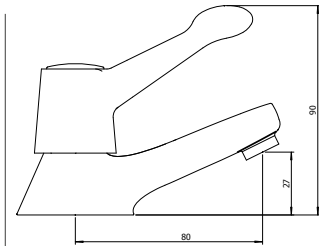
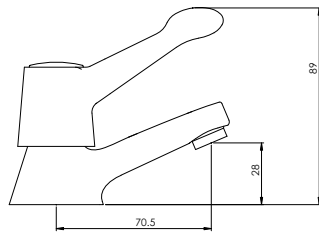

CODE	DESCRIPTION
922061	Basin Tap Pair

- Metal Backnut
- Low Pressure
- 2 YEAR Guarantee
- Flow Straightener
- Single Flow
- 13.1 l/min

CODE	DESCRIPTION
922063	Bath Tap Pair

- Metal Backnut
- Low Pressure
- 2 YEAR Guarantee
- Flow Straightener
- Single Flow
- 14.2 l/min

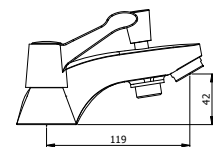
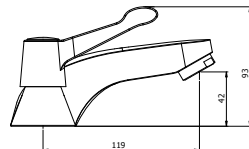

CODE	DESCRIPTION
922000	Bath Filler

- Metal Backnut
- Low Pressure
- 2 YEAR Guarantee
- Flow Straightener
- Single Flow
- 15.1 l/min

CODE	DESCRIPTION
922066	Bath Shower Mixer With Shower Kit

- Metal Backnut
- Low Pressure
- 2 YEAR Guarantee
- Flow Straightener
- Single Flow
- Shower Kit Included
- 11.0 l/min

MERCIA TRADITIONAL

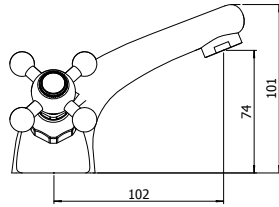

CODE DESCRIPTION
922086 Mono Basin Mixer

- Flexible Hose
- Low Pressure
- 10 YEAR Guarantee
- Flow Straightener
- Flow Aerator
- 11.5 l/min

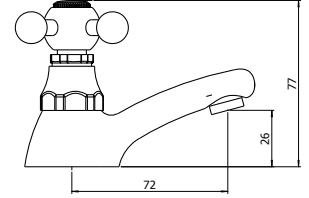

CODE DESCRIPTION
922089 Basin Tap Pair

- Metal Backnut
- Low Pressure
- 10 YEAR Guarantee
- Flow Straightener
- 17.0 l/min

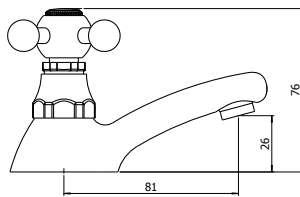

CODE DESCRIPTION
922088 Bath Tap Pair

- Metal Backnut
- Low Pressure
- 10 YEAR Guarantee
- Flow Straightener
- 17.5 l/min

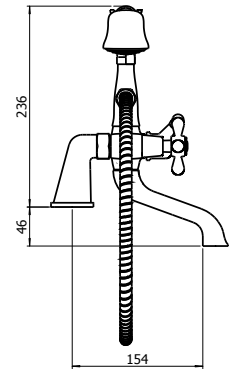

CODE DESCRIPTION
922087 Bath Shower Mixer with Shower Kit

- Metal Backnut
- Low Pressure
- 10 YEAR Guarantee
- Shower Kit Included
- 13.5 l/min

MERCIA QT

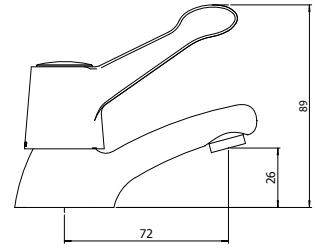
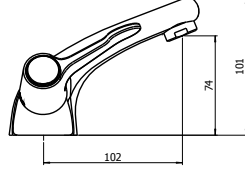

CODE	DESCRIPTION
351906	Mono Basin Mixer



Flexible Hose



Low Pressure



10 YEAR Guarantee



Flow Straightener



Flow Aerator



Single Flow



9.9 l/min

CODE	DESCRIPTION
351901	Basin Tap Pair



Metal Backnut



Low Pressure



10 YEAR Guarantee



Flow Straightener



Single Flow



13.2 l/min

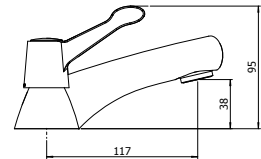
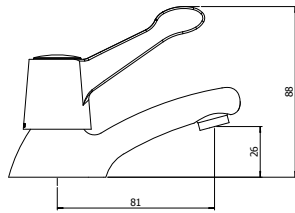

CODE	DESCRIPTION
351902	Bath Tap Pair



Metal Backnut



Low Pressure



10 YEAR Guarantee



Flow Straightener



Single Flow



14.9 l/min

CODE	DESCRIPTION
351904	Bath Filler



Metal Backnut



Low Pressure



10 YEAR Guarantee



Flow Straightener



Single Flow



15.5 l/min

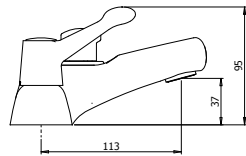

CODE	DESCRIPTION
351903	Bath Shower Mixer with Shower Kit



Metal Backnut



Low Pressure



10 YEAR Guarantee



Shower Kit Included



Flow Straightener



Single Flow



15.0 l/min

MERCIA MODERN

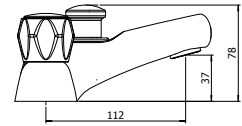
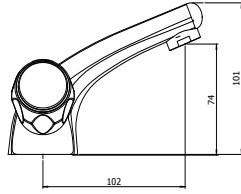

CODE	DESCRIPTION
4M3904	Mono Basin Mixer

Flexible Hose
 Low Pressure
 10 YEAR Guarantee
 Flow Straightener
 Flow Aerator
 Single Flow
 11.5 l/min

CODE	DESCRIPTION
4M3911	Bath Shower Mixer with Shower Kit

Metal Backnut
 Low Pressure
 10 YEAR Guarantee
 Flow Straightener
 Shower Kit Included
 Single Flow
 21.9 l/min

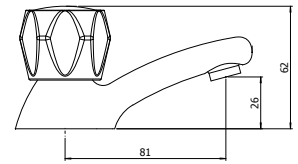
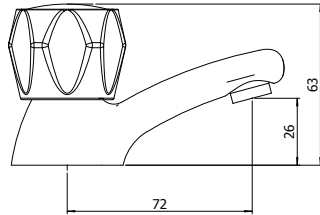

CODE	DESCRIPTION
4M3901	Basin Tap Pair

Metal Backnut
 Low Pressure
 10 YEAR Guarantee
 Flow Straightener
 Single Flow
 17.0 l/min

CODE	DESCRIPTION
4M3903	Bath Tap Pair

Metal Backnut
 Low Pressure
 10 YEAR Guarantee
 Flow Straightener
 Single Flow
 17.5 l/min

MERCIA CROSS TOP

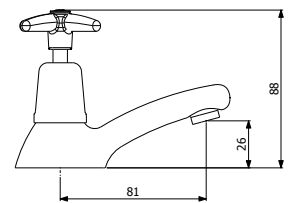
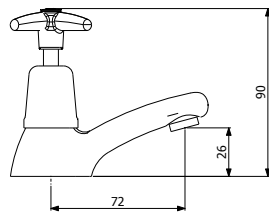

CODE	DESCRIPTION
350901	Basin Tap Pair

Low Pressure
 10 YEAR Guarantee
 Flow Straightener
 Single Flow
 10.2 l/min

CODE	DESCRIPTION
350902	Bath Tap Pair

Low Pressure
 10 YEAR Guarantee
 Flow Straightener
 Single Flow
 23.3 l/min

Showers





Product range

	Pages
Thermostatic Shower Mixers	24
Sliding Bar Sets & Shower Kits	25
Tech Air Shower Heads	26
Concealed Shower Mixers	27

THERMOSTATIC SHOWER MIXERS



CODE	DESCRIPTION
44440	Lujo Thermostatic Shower Mixer

- L**
Low Pressure
- Thermostatic Value
- 5**
YEAR
Guarantee

CODE	DESCRIPTION
44441	Araya Thermostatic Shower Mixer

- L**
Low Pressure
- Thermostatic Value
- 5**
YEAR
Guarantee



CODE	DESCRIPTION
44442	Thermostatic Square Bar Shower Mixer

- L**
Low Pressure
- Thermostatic Value
- 5**
YEAR
Guarantee

CODE	DESCRIPTION
4G4017	Wall Mounted Bath Shower Mixer with Shower Kit
4G4018	Deck Mounted Legs Pair

- L**
Low Pressure
- 10**
YEAR
Guarantee
- Thermostatic Value
- Shower Kit Included
- Brass

SLIDING BAR SETS & SHOWER KITS

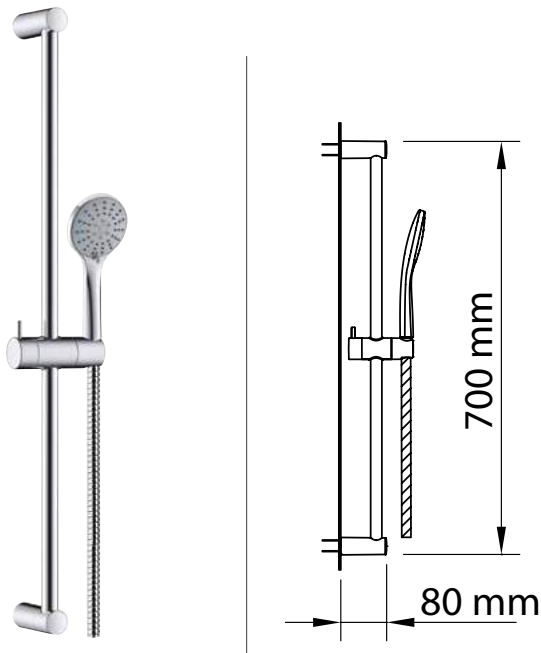

CODE	DESCRIPTION
923092	Barcino Sliding Bar Set

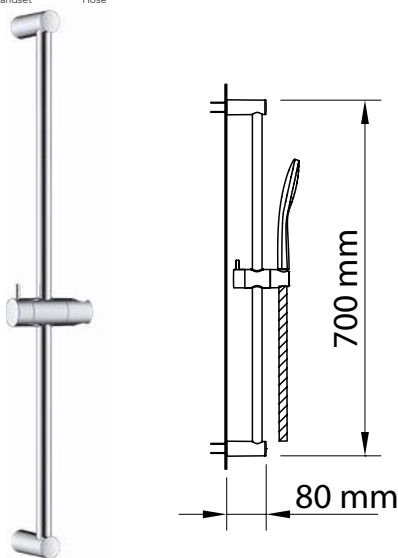

CODE	DESCRIPTION
923093	Barcino Sliding Bar

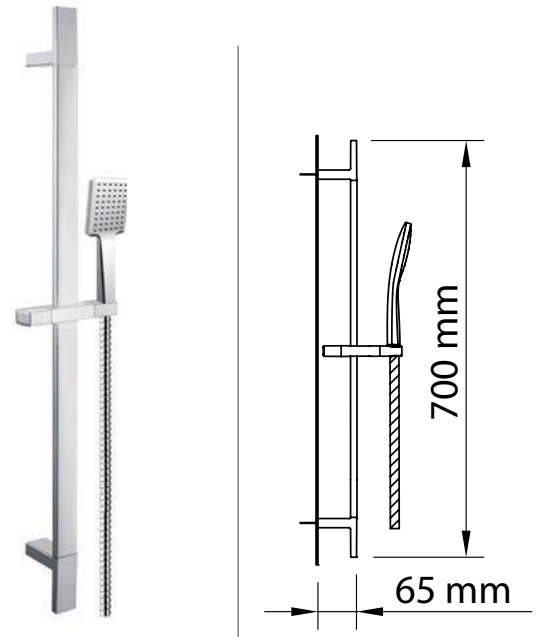

CODE	DESCRIPTION
923090	Barrio Sliding Bar Set



CODE	DESCRIPTION
467003	Shower Kit including Slider Rail & Soap Dish



TECH AIR SHOWER HEADS

5
YEAR

Guarantee



Tech Air
Rain Shower



Our shower heads use advanced Air Technology. Mixing Air with incoming water reducing the water consumption by at least 30%



CODE	DESCRIPTION
923060	Slim INOX Air 400mm x 400mm
923062	Slim INOX Air 250mm x 250mm
923063	Slim INOX Air 200mm x 200mm



Stainless Steel

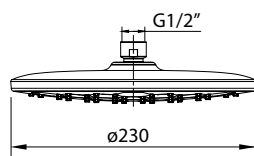

CODE	DESCRIPTION
923064	Slim INOX Air 300mm
923065	Slim INOX Air 200mm



Stainless Steel

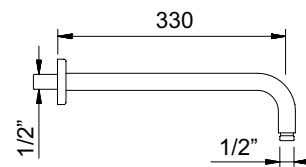

CODE	DESCRIPTION
923066	Hexagon Air 230mm



ABS

CODE	DESCRIPTION
923074	Luzia 330mm



Brass

CONCEALED SHOWER MIXERS

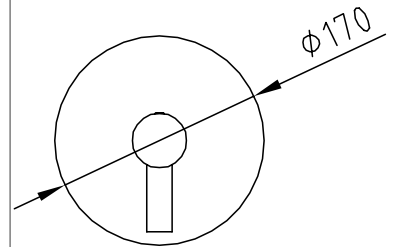
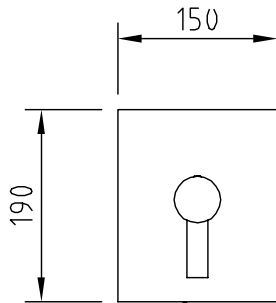

CODE	DESCRIPTION
923012	Artic Urban One Outlet



CODE	DESCRIPTION
923013	Bahama Xtreme One Outlet

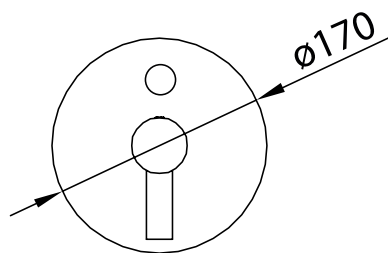

CODE	DESCRIPTION
923017	Bahama Two Outlet



Commercial Taps & Mixers





Product range

	Pages
Electric Sensor Mixers	30
Thermostatic Basin Mixer	30
Non-Concussive	31
Healthcare Solutions	33

ELECTRONIC SENSOR MIXERS

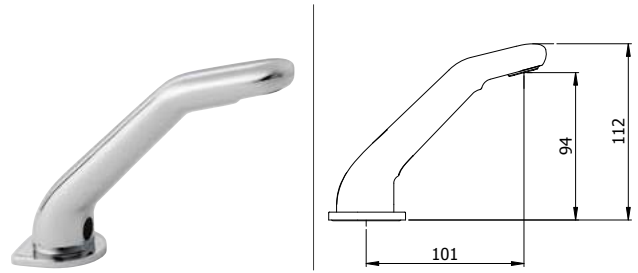
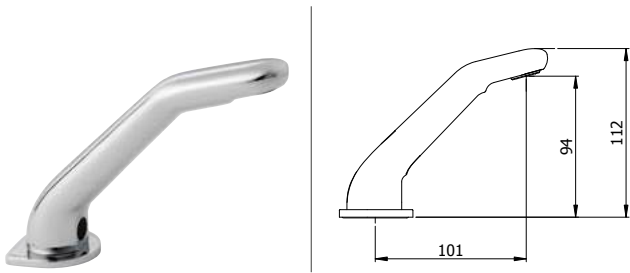

CODE	DESCRIPTION
343052	Observe Deck Mounted Infrared Sensor Tap 1/2" Battery



CODE	DESCRIPTION
343053	Observe Deck Mounted Infrared Sensor Tap 1/2" Mains

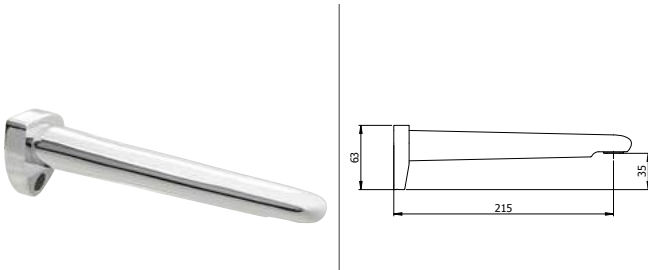

CODE	DESCRIPTION
343055	Observe Wall Mounted Infrared Sensor Tap 1/2" Mains



THERMOSTATIC

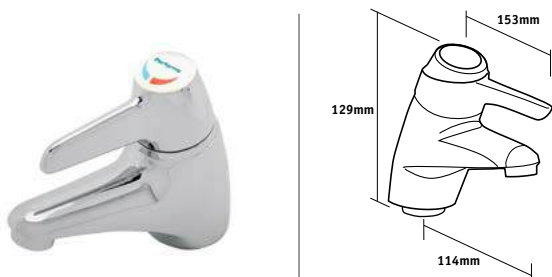

CODE	DESCRIPTION
360049	Thermostatic Basin Mixer



NON-CONCUSSIVE

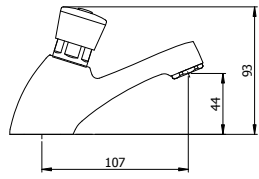

CODE	DESCRIPTION
349001	Non-concussive Basin Tap Pair including 2 x hot & cold indices

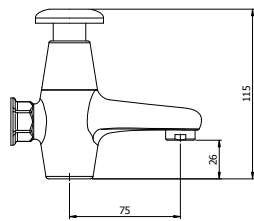

CODE	DESCRIPTION
360077	P88o Self Closing Bib Tap Hot
360078	P88o Self Closing Bib Tap Cold

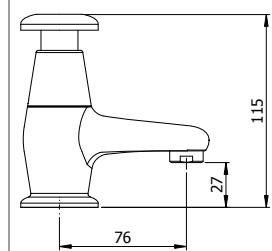

CODE	DESCRIPTION
360072	P876 Self Closing Basin Tap Hot
360073	P876 Self Closing Basin Tap Cold

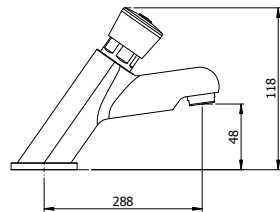

CODE	DESCRIPTION
360082	P875 Time Delay Basin Tap including hot & cold indices

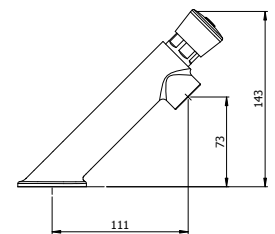

CODE	DESCRIPTION
360080	P877 Self Closing Basin Tap including hot & cold indices

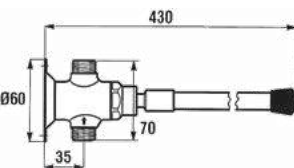

CODE	DESCRIPTION
342009	882 Lever Operated Flow Control

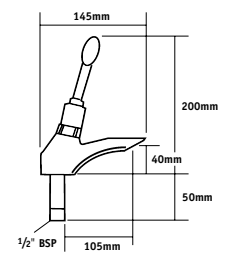

CODE	DESCRIPTION
341006	871-2 Lever Operated Self Closing Basin Tap





HEALTHCARE SOLUTIONS

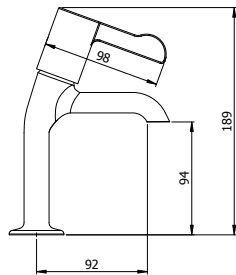

CODE	DESCRIPTION
360104	Sink Tap Pair

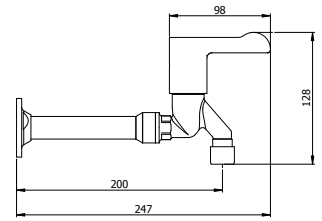

CODE	DESCRIPTION
360108	Wall Mounted Extended Bibtap Pair

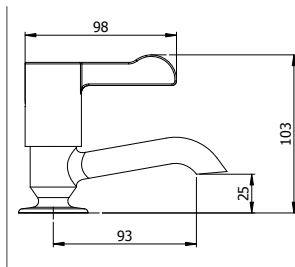

CODE	DESCRIPTION
360109	Long Nose Basin Tap Pair

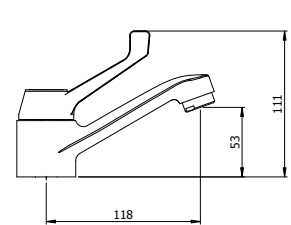

CODE	DESCRIPTION
319007	401 Healthcare Spray Basin Mixer



Accessories

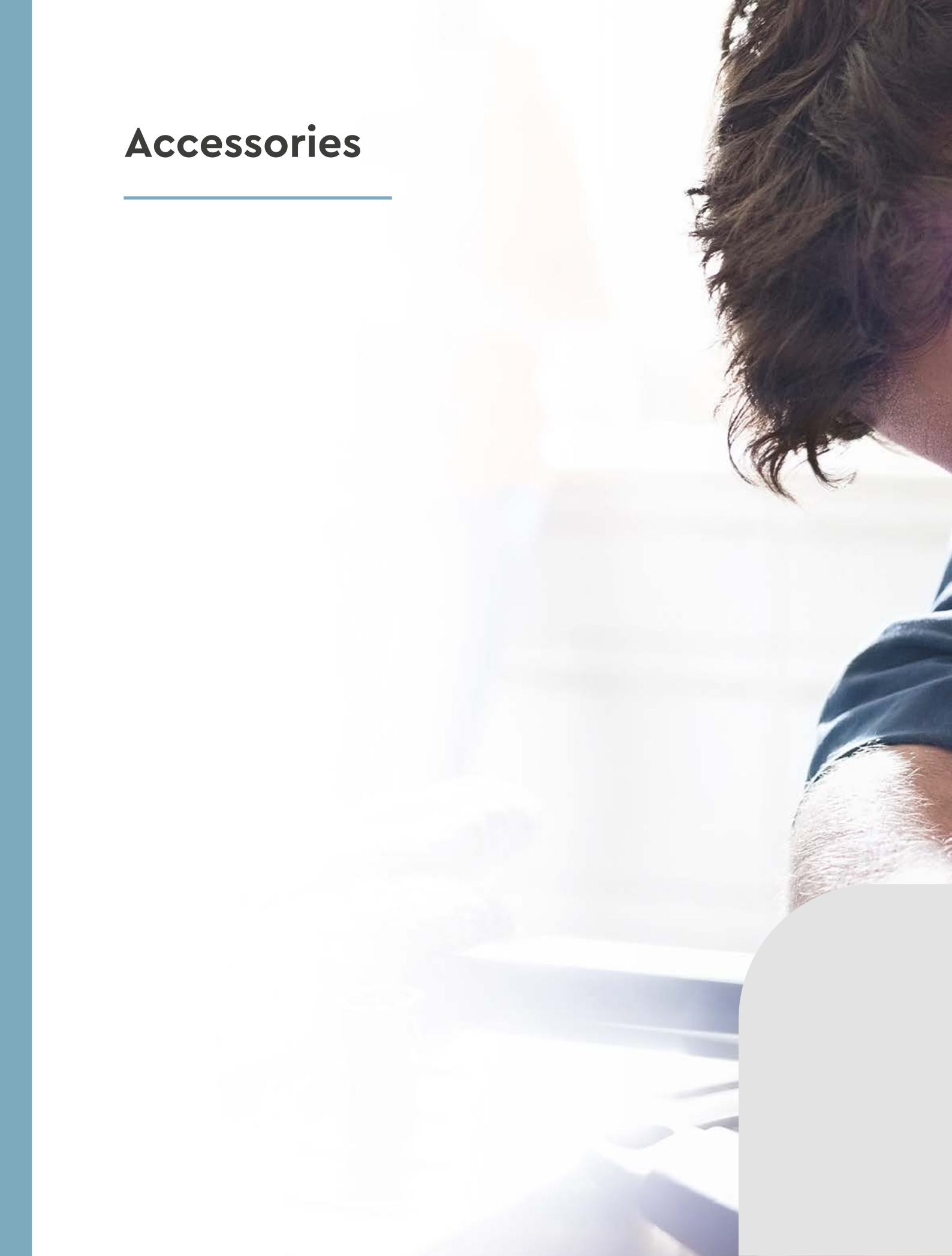



Product range

	Pages
Basin Wastes & Traps	36-37
Bath Wastes	38
Sink Wastes	39
Shower Wastes	39
Shower Accessories	40
Anti Scold Thermo Mixing Valves	40
Tap Conversion Kits	40
Flow Restrictors	41
Copper Inlet Tails	41
Replacement Filters	41

BASIN WASTES AND TRAPS



CODE	DESCRIPTION
854493	Basin Waste Slotted with Round Click Action Plug

CODE	DESCRIPTION
854784	Basin Waste Slotted with Square Click Action Plug

5
YEAR
Guarantee



5
YEAR
Guarantee



CODE	DESCRIPTION
47004	Basin Waste Slotted with Large Click Action Plug

CODE	DESCRIPTION
47005	Basin Waste Unslotted with Large Click Action Plug

2
YEAR
Guarantee



2
YEAR
Guarantee



CODE	DESCRIPTION
47006	Basin Waste Slotted with Small Click Action Plug

CODE	DESCRIPTION
47007	Basin Waste Unslotted with Small Click Action Plug

2
YEAR
Guarantee



2
YEAR
Guarantee



CODE	DESCRIPTION
47002	Basin Waste Slotted with Swivel Action Plug

CODE	DESCRIPTION
47003	Basin Waste Unslotted with Swivel Action Plug

2
YEAR
Guarantee



2
YEAR
Guarantee





CODE	DESCRIPTION
47065	Basin Waste Slotted Chrome Plug

2
YEAR

Guarantee



Metal
Backnut



CODE	DESCRIPTION
47019	Basin Waste Slotted with Chrome Plug

2
YEAR

Guarantee



Plastic
Backnut



CODE	DESCRIPTION
47020	Basin Waste Slotted with Poly Plug

2
YEAR

Guarantee



Plastic
Backnut



CODE	DESCRIPTION
47406	Minimalist Trap - Chrome

5
YEAR

Guarantee



CODE	DESCRIPTION
47068	Premium Black Basin Waste Slotted with Large Round Click

5
YEAR

Guarantee



Metal
Backnut

CODE	DESCRIPTION
47160	Basin Waste Unslotted with Poly Plug

2
YEAR

Guarantee



Plastic
Backnut



CODE	DESCRIPTION
47405	Bottle Trap Chrome - 35mm Outlet

5
YEAR

Guarantee



CODE	DESCRIPTION
47067	Modern Black Basin Trap

5
YEAR

Guarantee

BATH WASTES



CODE	DESCRIPTION
47063	Combined Bath Filler Waste & Overflow

5
YEAR
Guarantee



CODE	DESCRIPTION
47060	Deluxe Combined Bath Pop Up Waste & Overflow

5
YEAR
Guarantee



CODE	DESCRIPTION
47069	Deluxe Combined Bath Pop UP Waste & Overflow - Black

5
YEAR
Guarantee



CODE	DESCRIPTION
47001	Bath Pop-up Assembly Chrome

2
YEAR
Guarantee



CODE	DESCRIPTION
47062	Combined Bath Large Click Waste & Overflow

2
YEAR
Guarantee



CODE	DESCRIPTION
47032	Bath Combi Waste with Small Click Action Plug
47033	Bath Combi Waste with Large Click Action Plug

2
YEAR
Guarantee



CODE	DESCRIPTION
47031	Bath Combi Waste with Parking Plug

2
YEAR
Guarantee



CODE	DESCRIPTION
47056	Combined Waste & Overflow Chrome Plug

2
YEAR
Guarantee



CODE	DESCRIPTION
47040	Bath Combi Waste - S/S Grid

2
YEAR
Guarantee

SINK WASTES



CODE	DESCRIPTION
47066	Combined Sink Basket Strainer Waste & Overflow

5
YEAR
Guarantee



CODE	DESCRIPTION
526011	Sink Waste Slotted Poly Plug

2
YEAR
Guarantee



CODE	DESCRIPTION
47064	Combined Sink Poly Plug Waste & Overflow

2
YEAR
Guarantee



CODE	DESCRIPTION
526021	Sink Waste Unslotted Poly Plug

2
YEAR
Guarantee

CODE	DESCRIPTION
47230	Basket Strainer Waste S/S Grid

2
YEAR
Guarantee



SHOWER WASTES



CODE	DESCRIPTION
530023	Shower Waste, High Capacity with Trap & Adjustable Bend

5
YEAR
Guarantee

SHOWER ACCESSORIES



CODE	DESCRIPTION
44408	Fast Fix Wall Support Bracket

CODE	DESCRIPTION
48690	Shower Adaptor

ANTI SCOLD THERMOSTATIC MIXING VALVES



CODE	DESCRIPTION
05340	15mm Thermostatic Mixing Valve

CODE	DESCRIPTION
05341	22mm Thermostatic Mixing Valve



TAP CONVERSION KITS



CODE	DESCRIPTION
39201	1/2" BS5412 /1010 Tap Conversion Set Chrome
39203	3/4" BS5412 /1010 Tap Conversion Set Chrome

CODE	DESCRIPTION
39200	1/2" BS5412 /1010 Tap Conversion Set Acrylic
39202	3/4" BS5412 /1010 Tap Conversion Set Acrylic

FLOW RESTRICTORS

CODE	DESCRIPTION
343201	Basin Tap 4L Water Saving Regulators Pair
343202	Shower Restrictor
467037	High Pressure 4L Flexible Hose Water Saving Regulators Pair – Grey
467038	High Pressure 6L Flexible Hose Water Saving Regulators Pair – Black

COPPER INLET TAILS

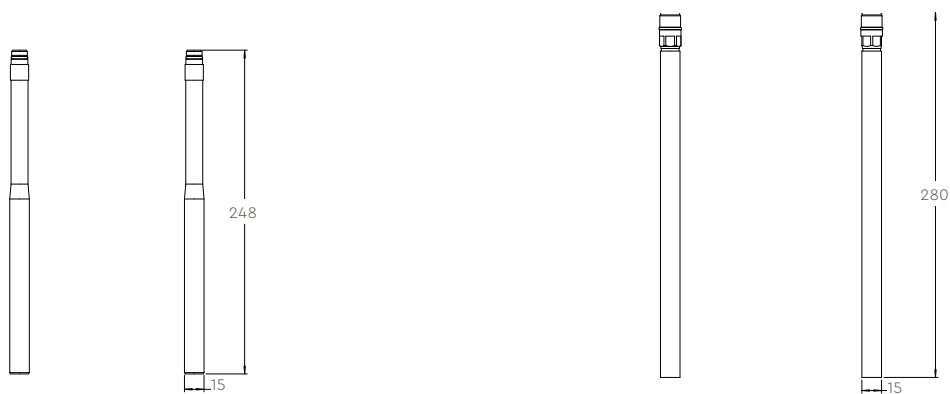

CODE	DESCRIPTION
856006	Trade M10 copper Tails

CODE	DESCRIPTION
856007	Trade M12 Copper Tails

REPLACEMENT FILTERS

CODE	DESCRIPTION
922209	Replacement Carbon Filter
922210	Water Filter Kit
922211	Water Filter Only

TERMS & CONDITIONS

GENERAL

In these conditions, reference to the Company shall mean STH WESTCO. All previous terms and conditions of sale are hereby cancelled, and only the following shall have effect from 1st January 2012. All quotations are made, and all orders are accepted subject to these conditions. All other terms, conditions or warranties whatsoever are excluded from the contract or any variation thereof unless expressly accepted by the Company in writing. In the event of a conflict between these conditions and the specific terms and conditions of quotation then the latter shall prevail.

ELECTRONIC TRADING

- a) If the Company and Buyer agree that electronic trading between them shall be a basis for order processing and invoicing then the Standard Interchange Agreement (1st Edition March 1989) of the EDI Association shall be incorporated into the contract by reference subject to these conditions.
- b) Electronic orders shall be valid if all the information agreed between the Buyer and the Company as being required is properly set out in the agreed format and the order is transmitted by the Buyer to the Company by reference to the correct identification code and is received by the Company when collecting its electronic mail from the relevant system.
- c) Each valid electronic order will be deemed accepted by the Company unless the Company communicates rejection of the order to the Buyer by electronic or other means (including telephone) within 24 hours of receipt. Acceptance of an order shall constitute a contract for sale and purchase to which these conditions and the Standard Interchange Agreement shall prevail.
- d) If the Company and the Buyer agree that invoicing may be done by electronic mail, then payment will be due 30 days after the date of electronic invoice unless agreed otherwise.

DELIVERY

Any date for delivery named by the Company is an estimate only and in no circumstances shall the failure of the Company to deliver on or before the named date either entitle the Buyer to rescind or terminate the contract or make the Company liable in any way for the consequences of any delay.

RETURNS

All returns must be reported within 3 working days of receipt of delivery, a 25% restocking fee will be applied to all returns with the exception of goods deemed to be faulty and are within the warranty period.

Any orders that require cancellation must be done so in writing prior to the order being processed through our warehouse. Following this, if an order is received, you must provide proof of cancellation before collection can be arranged. Please ensure items are packaged in a safe manor to avoid damage during transport, any items damaged on return will not receive a credit. It is mandatory to fill out a Westco Returns Form if a debit note is not provided, if a return is requested without either the return will be rejected.

EXPORT

Unless specifically stated otherwise in these conditions all trade terms not specifically covered by these conditions shall be interpreted in accordance with INCOTERMS current on the date of that order.

WARRANTY AND DEFECTIVE GOODS

- a) Save as otherwise provided by the other conditions of these Conditions, sections 12 to 15 of the Sale of Goods Act 1979 are to be implied into this contract.
- b) The goods delivered under the Contract shall, where the Contract includes a specification, comply with the specification or, if there is no specification, shall be of normal industrial quality.
- c) The Buyer does not rely on any statement or representations other than those

which have been made in writing by the Company.

d) The Buyer must give the Company immediate written notice of any defect in the goods. Such goods shall be returned to the Company, and if proved to have been defective at delivery as a result of faulty materials or workmanship, the Company shall at its option replace or repair such goods. Defects in quality or dimension in any delivery shall not be ground for cancellation of the remainder of the order.

e) Save for any liability for death or personal injury caused by the Company's negligence, the Company's liability in connection with defective goods shall be limited to the repair or supply of a replacement for the defective goods, and the Company shall not be liable for any other loss or damage including, but not limited to loss of profit, labour costs, damage to property, wasted expenditure or cost of mitigation.

DATA AND TECHNICAL INFORMATION

Illustrations, reference numbers, statement of weights or measures are not binding on the Company. The goods will be supplied substantially to the design described in the quotation. However, the Company reserves the right to make reasonable changes at his discretion during the execution of the Buyer's order. Every effort is made by the Company to ensure the accuracy of any technical data or literature made available in relation to the goods. However, the Company accepts no liability for any damage or injury arising from any errors or omissions in such technical data.

PATENT RIGHTS

- a) The sale of any goods and the publication of any information or technical data relating thereto does not imply freedom from the patent or other protective rights in respect of their application and the Company accepts no liability for infringement of such rights
- b) The Buyer shall indemnify the Company against all royalties or other payments in respect of any patent, registered designs or other rights which may be claimed as a result of goods being made according to design or specification supplied by the Buyer. The Buyer shall further indemnify the Company against all claims, expense and costs in connection with any infringement of any patent or registered design or other right in the manufacture of such goods.

CLAIMS FOR DAMAGE, SHORTAGE OR LOSS

No claim for damage in transit or shortage of delivery can be accepted unless, a separate notice in writing is given to the carrier concerned and to the Company within three days of receipt of the goods, followed by a complete claim in writing within five days of receipt of the goods. No claim for loss of goods in transit can be accepted unless a separate notice in writing is given to the carrier concerned and to the Company, and a complete claim in writing made within 3 days of the date of consignment. Where goods are accepted from the carrier concerned without being checked, the delivery book of the carrier must be signed "not examined". If a complaint is not made to the Company as herein provided, the products shall be deemed to be in all respects in accordance with the Contract, and the Buyer shall be bound to pay for the same accordingly.

SUSPENSION OF DELIVERIES

- a) Deliveries may be wholly or partially suspended by the company in the event of:-
 - i. Stoppage, delay or interruption caused to the business of the Company as a result of strikes, lockouts, trade disputes, breakdown, accident or any cause whatsoever beyond the reasonable control of the Company.
 - ii. Any default by the Buyer in making payment of any amounts owed to the Company under this and any other contracts between them.
- b) In the event of any hostilities (whether war is declared or not) in which Great Britain is involved, or in the event of national emergency, or if the Company's works should become either directly or indirectly engaged on Government orders as to prevent or delay work on other orders, the Company shall be entitled at any time, on notice to the Buyer, to make partial deliveries only or

to determine the contract without prejudice in any case to rights accrued in respect of deliveries already made. to the carrier concerned and to the Company, and a complete claim in writing made within 3 days of the date of consignment. Where goods are accepted from the carrier concerned without being checked, the delivery book of the carrier must be signed "not examined". If a complaint is not made to the Company as herein provided, the products shall be deemed to be in all respects in accordance with the Contract, and the Buyer shall be bound to pay for the same accordingly.

DETERMINATION OF CONTRACT

The Company shall have the right forthwith to determine this and/or any other Contract between the Buyer and the Company by written notice to the Buyer's last known address (without prejudice to any claim or right the Company might otherwise make or exercise) in any of the following events:-

- a) If the Buyer shall make default in or commit a breach of any contract with the Company; or
- b) If any distress or execution shall be levied upon the Buyer's property or assets; or
- c) If the Buyer shall make or offer to make any arrangements or composition with creditors, or commit any act of bankruptcy or become insolvent; or
- d) If any petition or receiving order in bankruptcy shall be presented or made against him; or
- e) If the buyer shall be a limited Company and become subject of any resolution or petition for winding up or administration; or
- e) If a receiver or manager of the Buyer's undertaking, property or assets or any part thereof shall be appointed.

INDEMNITY

The Buyer will indemnify the Company against all damages, penalties, costs and expenses to which the Company may become liable as a result of work done to the Buyer's instructions or which infringe any letters, patent or registered design or copyright or any other third-party intellectual property rights.

PRICES

The price payable for the goods shall be those previously agreed with the Company unless otherwise stated and current at the date of despatch. Such prices may be subject to a delivery charge which shall be levied to the Buyer.

RISK AND TITLE

- a) Risk shall pass to the Buyer so that the Buyer is responsible for all loss, damage or deterioration to the goods:
 - i. If the Company delivers the goods by its own transport at the time when the goods or a relevant part thereof arrive at the place of delivery; or
 - ii. In all other circumstances at the time when the goods, or a relevant part thereof leave the premises of the Company whether or not the Company arranges transport and (without prejudice to clause 7) where the goods are delivered by carrier, any claims for loss or damage in transit must be made by the Buyer against the carrier in accordance with the carrier's conditions.
- b) Title to the goods supplied under the contract shall only pass to the Buyer when payment in full for all goods supplied under this and all other contracts between the Company and the Buyer has been received by the Company. The Company reserves the immediate right to possession of and at any time may recover all goods in respect of which title has not passed to the Buyer; the Company is hereby authorised by the Buyer to enter upon any premises where such goods are held by or on behalf of the Buyer and recover possession thereof.
- c) Until title to goods has been passed to the Buyer pursuant to these conditions it shall possess the goods as a Bailee at will of the Company, and the Buyer shall not be entitled to sell or otherwise deal in goods in respect of which title has not passed to the Buyer. If the Buyer acts in breach of these conditions

then without prejudice to any other rights of the Company the Buyer shall have a fiduciary duty to account to the Company for the proceeds of any sale save to the extent that any such proceeds exceed the amounts owed to the Company under this and all other contracts between the Company and the Buyer.

CANCELLATION

Cancellation will only be accepted by the Company on condition that all costs and expenses incurred by the Company up to the time of cancellation and all loss of profits and other loss or damage suffered by the Company as a result of such cancellation will be paid forthwith by the Buyer to the Company.

PAYMENT OF ACCOUNTS

- a) Unless otherwise agreed by the Company in writing, payment shall be settled in full by the last working day of the month following the month in which the goods were despatched, or would have been despatched save for postponement otherwise than due to default on the part of the Company. The Company shall be entitled to submit its invoice on the same day as its delivery advice note or at any time thereafter, save that where delivery has been postponed at the request of or the default of the Buyer, then the Company may submit its invoice at any time after the goods are ready for delivery or would have been ready in the ordinary course but for the request or default as aforesaid.
- b) The Company reserves the right to charge interest at a rate up to 5% above Lloyds Bank Base Lending Rate ruling at the time payment is due if payment is not made in accordance with the terms agreed at the time the order is accepted.

VAT

The prices quoted are exclusive of VAT, which will, if applicable, be added to the invoice at the rate then current.

CONSUMER PROTECTION ACT

In circumstances where the Company supplies parts or goods to the Buyer for incorporation with, or use ancillary to, any composite goods to be produced, manufactured, processed or supplied by the Buyer then:

- a) The Buyer shall forthwith on demand produce for inspection by the Company copies of all written instructions, information and warnings in relation to the said composite goods, provided nevertheless that such inspection or right to inspect shall not of itself constitute acceptance or approval on the part of the Company of such instructions, information, or warnings; and
- b) The Buyer shall indemnify, reimburse and compensate the Company for all losses and damages (including costs, expenses and charges for legal actions in which the Company may be involved) that the Company may incur in the event that any claim or claims are made against the Company pursuant to the Act relating to the said composite goods of the Buyer or parts or goods supplied hereunder in circumstances in which the parts or goods supplied by the Company was either:
 - i. Not the defective part of the said composite goods; or
 - ii. Was only rendered the defective part or became defective goods by reason of actions or omission of the Buyer; or
 - iii. Was only rendered the defective part or became defective goods by reason of instructions or warnings given or omitted by the Buyer or other supplier of the said composite goods supplied hereunder.
- c) For the purposes of this condition the word "defective" shall be interpreted in accordance with the definition contained in the Act and this condition shall mutatis mutandis apply in relation to equivalent legislation of other states as it applies in relation to the Act.

LAW AND JURISDICTION

This contract shall be governed and construed according to the Law of England and the parties hereby agree to submit to the exclusive jurisdiction of the English courts.

Francis is a brand of



OUR FOUR AREAS OF EXPERTISE



THERMOSTATIC, AND MANUAL RADIATOR VALVES

The valves and fittings in our highly acclaimed heating series range from stylish chrome TRVs, to hardwearing everyday fittings which have become toolkit essentials for installers throughout the UK.



BRASSWARE

Our range of durable, high performing valves includes standard products for everyday plumbing and heating maintenance alongside a series of innovative valves specifically designed for additional safety and efficiency.

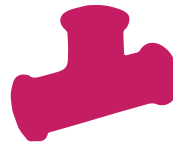

FITTINGS

WESTCO invest a great deal of time and energy in developing and sourcing products that satisfy the most demanding of plumbing requirements.



TAPS, MIXERS & SHOWERS

Combining style with practicality, our market-leading products are designed, developed and manufactured using the best materials available. We also apply stringent quality control standards to ensure outstanding reliability and the assurance of a long and robust working life.

ADDRESS

Unit C6, William Way, Moss Ind. Est.,
St. Helens Road,
Leigh, Lancashire
WN7 3PT

SALES & GENERAL ENQUIRIES

sales@francistaps.co.uk
Tel: 01942 603 351
Fax: 01942 607 780

www.francistaps.co.uk
www.westco.co.uk